



F300 Megablock series

passive hubs for general purpose, Zone 2 & Division 2 fieldbus networks

- Single-piece Trunk In/Trunk Out connector simplifies installation and maintenance
- Pluggable trunk and spur surge protection option
- Choice of rising cage clamp screw or spring clamp terminals
- Locate Megablock in Zone 2 or Division 2
- Connect to Ex nA, Ex nL, Ex ic devices in Zone 2/Division 2
- Connect to Ex d, explosionproof devices in Zone 1/Division 1



F300 Megablocks are DIN-rail mounted **passive hubs** for FOUNDATION™ fieldbus H1 and Profibus PA networks for general purpose, Zone 2 and Division 2 applications. They provide a simple means of connecting field devices to the network trunk cable, and protect the segment from spur short circuits. Megablocks minimize hand wiring and allow individual devices to be added to and removed from the segment without disrupting network communication. A green power LED on each unit indicates whether at least 10V dc is present. F300 Megablocks are available in four, eight, and twelve drop versions.

The **black Trunk In/Out pluggable connector** allows replacement of a Megablock without breaking the trunk connection to other devices on the fieldbus segment. The F97 terminator supplied should be mounted in the Trunk-out connection to provide termination when the Megablock is located at the end of the fieldbus segment; alternatively, if the segment is extended, it can be removed to ensure the correct termination is maintained.

Spur connections to the Megablock are made using pluggable, grey, screw-terminal or spring clamp terminal connectors. Wire terminations can be made to the individual connectors before plugging them into the Megablock. Devices can then be connected and disconnected easily during commissioning. After commissioning, retaining screws are tightened to secure each connector to the Megablock. Separate numbered connections are provided for each spur drop.

SpurGuard™ is a **device-port, short circuit protection technique** that minimizes susceptibility to single points of failure. The F300 Megablock has built-in SpurGuard™ protectors that prevent a short circuit in any of the individual field devices or spur cable runs, from bringing down the entire fieldbus segment. A red LED near each spur connection indicates when a spur is shorted and hence in "over-current" mode.

The optional FS32 modules can provide surge protection for the F300 products on both the trunk and spur terminals. These pluggable modules are simple to fit in a new installation, or as a retrofit option.

A range of MTL Process Junction Boxes in stainless steel and carbon loaded, glass-reinforced polyester are available for mounting Megablock wiring components. They offer plenty of space for termination and wiring, making it easy to install and maintain the fieldbus system.

F300 Megablock hazardous area approvals permit installation in a variety of configurations in Zone 2 and Division 2 hazardous areas. The F300 Megablock may be installed with non-sparking (non-arcing) or energy-limited (non-incendive) trunk and spur connections. Additionally, the F300 Megablock may be installed with a non-sparking (non-arcing) trunk with non-incendive, energy-limited Ex nL or intrinsically safe Ex ic spur connections.

When installed on a non-sparking trunk with Ex ic spurs, an F300-A01 trunk-spur partition must be installed on the F300 Megablock. The trunk-spur partition is supplied as a pack of 5, as detailed in the Accessories section of this document.

INSTALLATION

Megablocks can be mounted vertically or horizontally using 35mm DIN rail within a suitable enclosure, such as a field junction box. MTL have a wide range of standard junction box designs for use with Megablocks. See the data sheet for the range of Process JB's.

F300 Megablocks can be clipped onto or removed from the DIN rail without any tools. Use of DIN rail end stops is recommended to prevent sliding in vertical installations.

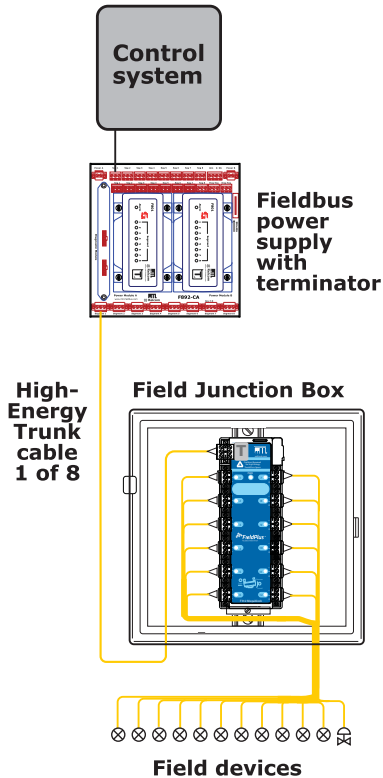

Shown above is an example of a common Fieldbus segment topology. Twelve field devices are connected to a twelve-drop Megablock, which is mounted in a field junction box. The trunk connector on the Megablock is wired to the segment trunk cable that leads to the control room or marshalling panel where the power supply and second terminator are located.

GROUNDING

To prevent ground loops, the fieldbus segment shield should only be grounded at one point. This is usually done by grounding the cable shield at the control room end of the segment.

SURGE PROTECTION - (see right)

The design of the F300 has made the installation of effective surge protection on trunk and spur cabling a simple matter, through the use of individual FS32 modules. Grounding bars are available, that clip easily onto the Megablocks to provide both mechanical support for the FS32 modules as well as a way of connecting them to a local low-impedance ground point to dissipate any induced surge currents.

See the **ACCESSORIES** section on the rear page to select the appropriate grounding bar(s) for the F300 model used and the necessary FS32 modules. A full technical datasheet for the FS32 is available from the MTL website.

SPECIFICATIONS

Mounting requirements

35mm DIN rail

Wire capacity

0.14 to 2.5mm²

Case material

Polycarbonate

Temperature range

Operating -45° to +70°C

Storage -50° to +85°C

Voltage required to activate power LED

10.0V dc minimum

Minimum input voltage

No. of Ports	4	8	12
V	10.4	10.5	10.6

Maximum input voltage

see certification ratings

Minimum spur output voltage

9.35V

Maximum input current

see certification ratings

Trunk-to-trunk voltage drop

0.1V maximum

Unloaded current consumption (maximum)

No. of Ports	4	8	12
mA	3.2	4.8	6.5

Spur device current

38mA maximum (recommend one device per spur)

Spur short-circuit current

56mA maximum

Trunk-to-spur voltage drop

1.25V maximum

PHYSICAL NETWORK

IEC 61158-2

Foundation™ fieldbus H1

Profibus PA

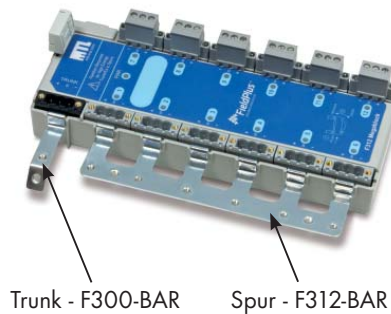

Grounding bars on an F312 model.

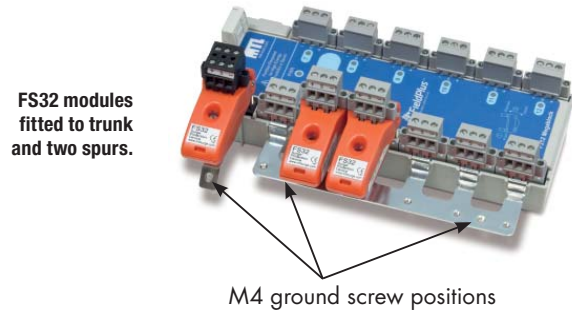

FS32 modules fitted to trunk and two spurs.

M4 ground screw positions

The given data is only intended as a product description and should not be regarded as a legal warranty of properties or guarantee. In the interest of further technical developments, we reserve the right to make design changes.



EUROPE (EMEA): +44 (0)1582 723633
enquiry@mtl-inst.com

THE AMERICAS: +1 800 835 7075
csinfo@mtl-inst.com

ASIA-PACIFIC: +65 6 487 7887
sales@mtlsing.com.sg

F300:
PS-072 RevA.0
F300 Product Specification
www.relcominc.com

CASE DIMENSIONS

4-WAY - F304

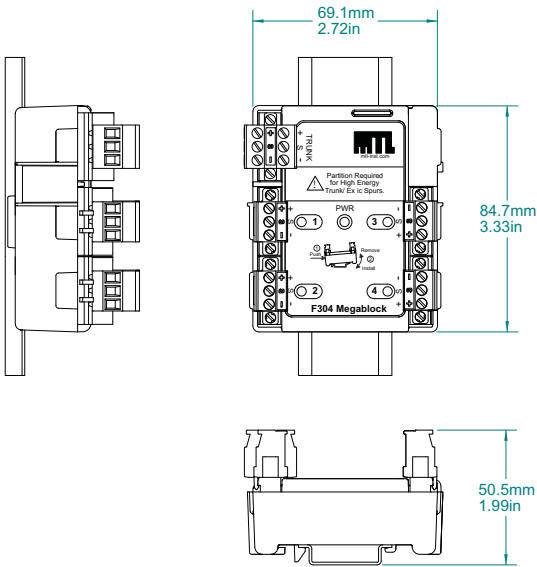

12-WAY - F312 (showing trunk-spur partition)

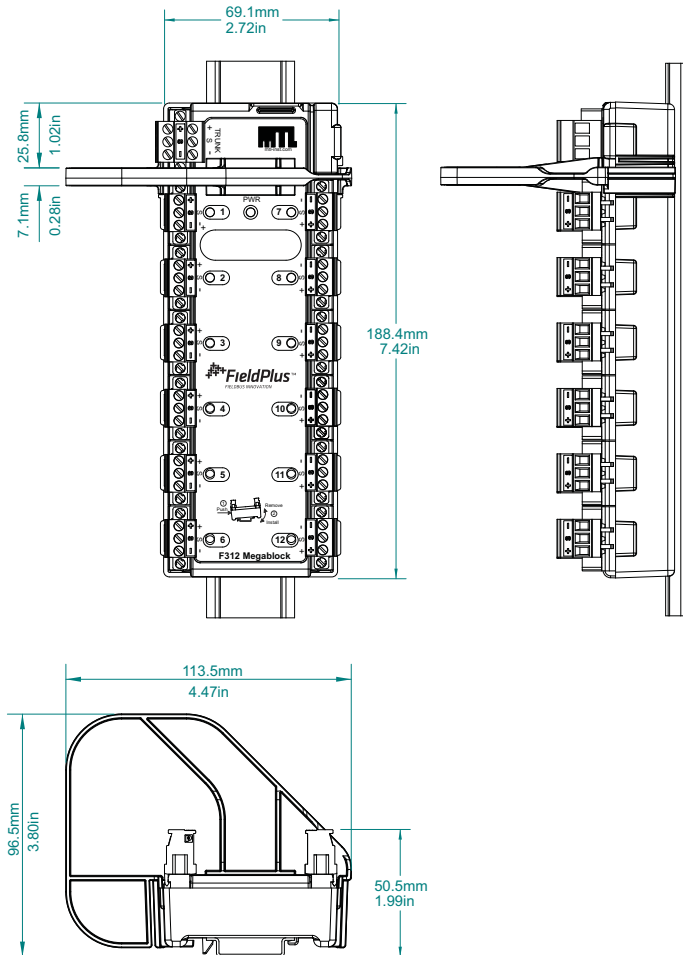

8-WAY - F308

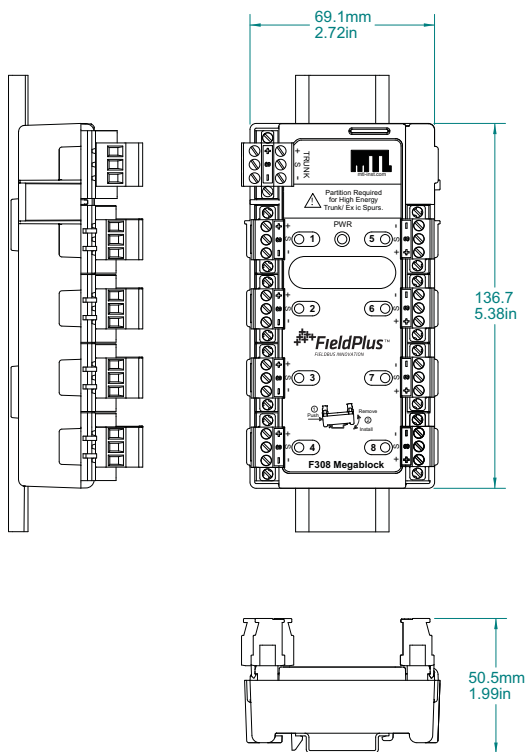

Note: Different Megablock versions have minor variations in labelling.

The given data is only intended as a product description and should not be regarded as a legal warranty of properties or guarantee. In the interest of further technical developments, we reserve the right to make design changes.



EUROPE (EMEA): +44 (0)1582 723633
enquiry@mtl-inst.com

THE AMERICAS: +1 800 835 7075
csinfo@mtl-inst.com

ASIA-PACIFIC: +65 6 487 7887
sales@mtlsing.com.sg

F300:
PS-072 RevA.0
F300 Product Specification
www.relcominc.com

APPROVALS - for full certification information visit www.mtl-inst.com/support/certificates/

Country	Europe			International		
Authority	ATEX (Category 3)			IECEX		
Standard	EN 60079-0 : 2006, 2009 EN 60079-15 : 2005, 2010	EN 60079-0 : 2006, 2009 EN 60079-11 : 2007 EN 60079-15 : 2005, 2010	EN 60079-0 : 2006, 2009 EN 60079-11 : 2007 EN 60079-27 : 2008	IEC60079-0 : 2004, 2007-10 IEC 60079-15 : 2005-03, 2010	IEC60079-0 : 2004, 2007-10 IEC 60079-11 : 2006 IEC 60079-15 : 2005-03, 2010	IEC60079-0 : 2004, 2007-10 IEC 60079-11 : 2006 IEC 60079-27 : 2008
Approved for	Ex nA [nL] IIC T4	⊕ II 3 GD Ex nA [ic] IIC T4*	⊕ II 3 GD Ex ic IIC T4	Ex nA [nL] IIC T4	Ex nA [ic] IIC T4*	Ex ic IIC T4
Certificate no.	RELC11ATEX1010X	RELC11ATEX1010X	RELC11ATEX1010X	IECEX FMG 11.0017	IECEX FMG 11.0017	IECEX FMG 11.0017
Apparatus parameters (Trunk)	Non-arcing	Non-arcing U _i = 32V I _i = 2A C _i = 0 L _i = 0	Energy Limited FISCO ic	Non-arcing	Non-arcing	Energy Limited FISCO ic
Cable parameters (Spur)	Energy limited U _o = U _o of power supply I _o = 56mA, C _o = 80nF L _o = 0.26mH	Energy limited U _o = 36V or U _o of power supply with voltage limiting to EN 60079-11 I _o = 56mA, C _o = 80nF L _o = 0.26mH	Energy Limited FISCO ic	Energy limited U _o = U _o of power supply I _o = 56mA, C _o = 80nF L _o = 0.26mH	Energy limited U _o = 36V or U _o of power supply with voltage limiting to IEC 60079-11 I _o = 56mA, C _o = 80nF L _o = 0.26mH	Energy Limited FISCO ic

* An F300-A01 trunk spur partition must be installed for Ex nA [ic] applications. See **Accessories** below.

Country	USA		Canada	
Authority	FM	FM	FMc	FMc
Standard	3600 1998 3611 2004 3810 2005 ANSI/ISA 60079-0 2009 ANSI/ISA 60079-15 2009	3600 1998 3611 2004 3810 2005 ANSI/ISA 60079-0 2009 ANSI/ISA 60079-15 2009	CSA C22.2 No. 213 :1987 CSA E60079-0: 2002 CSA E60079-15: 2002 CSA C22.2 No. 61010.1: 2004	CSA C22.2 No. 213 :1987 CSA E60079-0: 2002 CSA E60079-15: 2002 CSA C22.2 No. 61010.1: 2004
Approved for	NI/II/2/ABCD/T4 Ta=70°C I/2/IIC/T4 Ta=70°C	NI/II/2/ABCD/T4 Ta=70°C I/2/IIC/T4 Ta=70°C	NI/II/2/ABCD/T4 Ta=70°C I/2/Ex nA [nL] IIC T4 Ta=70°C	NI/II/2/ABCD/T4 Ta=70°C Ex nA IIC T4 Ta=70°C
Certificate no.	3041271	3041271	3041271C	3041271C
Apparatus parameters (Trunk)	Non-arcing	Non-arcing	Non-arcing	Non-arcing
Cable parameters (Spur)	Non-arcing	Non-incendive field wiring V _{oc} = V _{max} power supply < 32V I _{sc} = 56mA C _a = 80nF L _a = 0.26mH	Energy limited V _{oc} = V _{max} power supply < 32V I _{sc} = 56mA C _a = 80nF L _a = 0.26mH	Non-arcing

ORDERING INFORMATION

- F304** 4 way Megablock – screw terminals - including F97 terminator
- F308** 8 way Megablock – screw terminals - including F97 terminator
- F312** 12 way Megablock – screw terminals - including F97 terminator

- F304-PC** 4 way Megablock – spring-clamp terminals - including F97 terminator
- F308-PC** 8 way Megablock – spring-clamp terminals - including F97 terminator
- F312-PC** 12 way Megablock – spring-clamp terminals - including F97 terminator

ACCESSORIES

- F300-A01-5** Trunk-spur partition – pack of 5
- FS32*** Fieldbus Surge Protector
- F300-BAR-5** Pack of 5 F300 trunk bars
- F304-BAR-10** Pack of 10 F304 spur bars (two F304-BARs required for each F304)
- F308-BAR-10** Pack of 10 F308 spur bars (two F308-BARs required for each F308)
- F312-BAR-10** Pack of 10 F312 spur bars (two F312-BARs required for each F312)

* See datasheet on MTL web site for full technical specification

The given data is only intended as a product description and should not be regarded as a legal warranty of properties or guarantee. In the interest of further technical developments, we reserve the right to make design changes.