



- ◆ Redundant fieldbus power for FOUNDATION fieldbus™ cards
- ◆ High-density, compact design
- ◆ Fully isolated
- ◆ Hot swappable power modules*
- ◆ Low power dissipation
- ◆ Zero component carrier
- ◆ On-line diagnostics option
- ◆ Redundant power & conditioning
- ◆ Vertical DIN-rail mounting
- ◆ F801 output 21.5V, 350mA
- ◆ F802 output 28V, 500mA

The F890 fieldbus power system is designed to provide redundant power for eight FOUNDATION fieldbus™ H1 segments when used with the Emerson DeltaV or another non-proprietary cabled fieldbus system. Power for the fieldbus segments is provided by two power modules - F801s or F802s - operating in redundant configuration (load sharing). Failure alarms, galvanic isolation, power conditioning and segment termination are incorporated into each F80x module. In simplex applications, a single F80x module may be used. Termination of the fieldbus segments is automatically maintained when single or redundant F80x modules are fitted.

For extreme reliability, the module carrier has *no components* and only provides interconnections between the power modules and external connections. It is supported in a rigid metal frame that protects the circuit board from mechanical damage. Secure DIN-rail mounting is provided by integrated fixings.

Each F80x module monitors the output of the eight fieldbus segments and indicates an alarm by means of a built-in, normally closed relay if any of the segments is shorted, or below the minimum output voltage threshold. Failure of either of the bulk power input supplies is also annunciated. The alarm contacts are volt-free and galvanically isolated from other circuitry. Connections to the alarm relays are made via terminals on the F890-CA carrier. A separate

alarm module is not required for this function. LED indicators also show the status of each F801 module and the eight individual segments. In normal operation, each segment LED is lit, showing that the segment is powered. If a segment is shorted, this LED is extinguished, and the module Alarm LED is lit.

A separate physical layer diagnostics module may be installed on the carrier to automatically collect and distribute additional diagnostic information for each of the eight fieldbus segments. For more information see the F809F product specification.

The F80x module provides galvanic isolation between the 24V DC input power and the fieldbus segments, as required by the IEC61158-2 fieldbus standard and the Fieldbus Foundation™ FF-831 validation test for power supplies. There is also galvanic isolation between the fieldbus segments, thereby preventing multiple segment failures due to ground faults on more than one segment. Each segment has its own fieldbus power conditioner and current limitation.

Redundant 24V DC (nom.) input power is connected to the F890 carrier using two-part pluggable connectors. Field wiring connections are available with either pluggable screw terminals (F890-PS), or pluggable spring clamp terminals (F890-PC).

* Gas clearance certificate needed in Zone 2 hazardous areas

FOUNDATION fieldbus™ is a trademark of Fieldbus Foundation™, Austin, Texas.

SPECIFICATION

Location of equipment

Safe area,
Class I Div 2 Groups ABCD T4* or
Class I Zone 2 IIC T4*
*F802 power module certification is pending

INPUT

	F801	F802
Input voltage (DC)	19.2 - 30.0V	19.2 - 30.0V
Current consumption (24V input, all outputs fully loaded)	3.5A*	6A*
Total Power dissipation (24V input, all outputs fully loaded)	20W*	24W*

* Redundant operation

OUTPUT

	F801	F802
Number of channels	Eight (8)	Eight (8)
Voltage (DC)	21.5V - 24.0V	28.0V - 30.0V
Design current (per segment)	0 to 350mA	0 to 500mA
Current limit	> 370mA	> 520mA
Minimum load	0mA	0mA

Isolation

Fieldbus to input power: 250V AC rms withstand
Segment to segment: 200V DC withstand

ALARMS

Alarm contact rating

1A maximum @ 30V DC maximum

Alarm contact status

Normally closed

Alarm threshold

	F801	F802
Segment output	<19V DC	<24V DC

ELECTRICAL CONNECTIONS

System, Field, Power & Alarm terminals

Pluggable rising cage-clamp screw terminals (-PS)
Conductor size: 0.14 to 2.5 mm²
Pluggable spring-clamp screw terminals (-PC)
Conductor size: 0.2 to 2.5 mm²

Chassis ground

2-way fixed screw terminal connector 0.14 to 2.5 mm²

Terminators

A single termination is provided automatically when using either 1 or 2 power modules

ENVIRONMENTAL

Ambient temperature	F801	F802
Operating (full load)	-40°C to +65°C	-40°C to +50°C
Operating (60% load)	-40°C to +65°C	-40°C to +65°C
Storage	-40°C to +85°C	-40°C to +85°C

Note: Temperature range applies only when fitted to a vertical DIN rail mounted on a vertical plane.

Ingress protection

IP20 to BS EN60529 (Additional protection by use of enclosure)

MECHANICAL

Mounting method

Integrated fixings for 'Top hat' DIN rail, 35mm x 7.5mm to EN50022

ELECTRICAL

EMC Compliance

To EN61326:1998 Electrical equipment for measurement, control and laboratory use - EMC requirements

F890 - BLOCK DIAGRAM

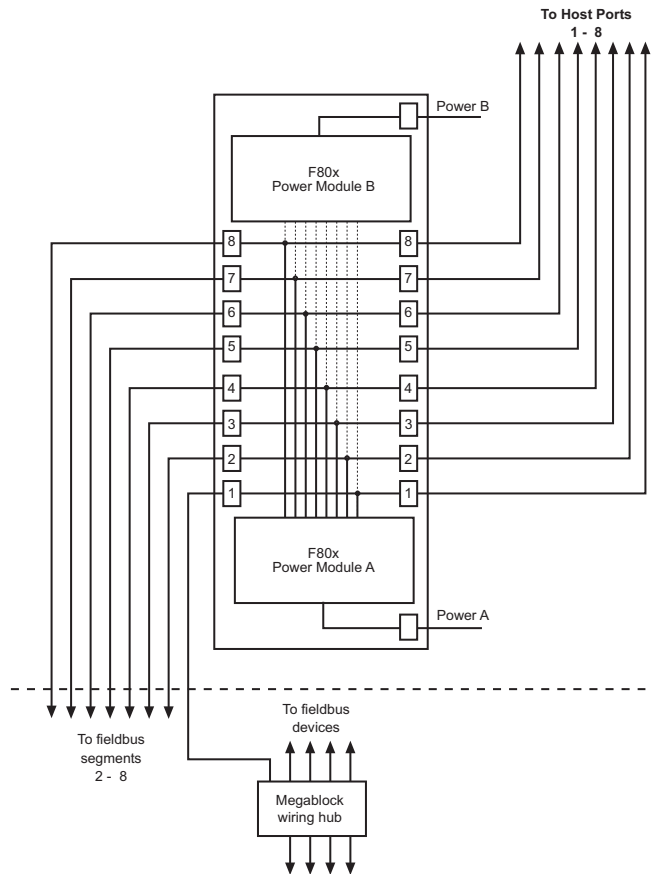

The above diagram shows a block diagram of how the F890 is wired. Note that the Chassis Ground and Alarm connection are not shown. The Diagnostic module is also not shown (see the F809F product specification). For detailed wiring information see the Installation Instructions for the F890 (Document number 502-090).

PHYSICAL NETWORKS

IEC61158-2
ISA-S50.02 Part 2-1992
FOUNDATION fieldbus™ H1
Profibus PA

ORDERING INFORMATION

DESCRIPTION

Carrier, unpopulated

8-segment power module: 21.5V, 350mA

8-segment power module: 28V, 500mA

F890-CA-P* and two F801 modules

F890-CA-P* and one F801 module

F890-CA-P* and two F802 modules

F890-CA-P* and one F802 module

Blanking modules included with -NR systems

Fieldbus diagnostic module

* = S or C S = Pluggable Screw Terminal Connectors

C = Pluggable Spring Clamp Connectors

PART NO

F890-CA-P*

F801

F802

F890-P*

F890-P*-NR

F890-2-P*

F890-2-P*-NR

F800-BLK

F809F

Product specifications are subject to change without notice



EUROPE (EMEA)
AMERICAS
ASIA PACIFIC

Tel: +44 (0)1582 723633
Tel: +1 281 571 8065
Tel: +65 6 487 7887

Fax: +44 (0)1582 422283
Fax: +1 281 571 8069
Fax: +65 6 487 7997

E-mail: enquiry@mtl-inst.com MTL web site: www.mtl-fieldbus.com Relcom web site: www.relcominc.com

F890:
PS-056 F890 Product Specification
Revision: F
www.relcominc.com

F801 PARAMETERS

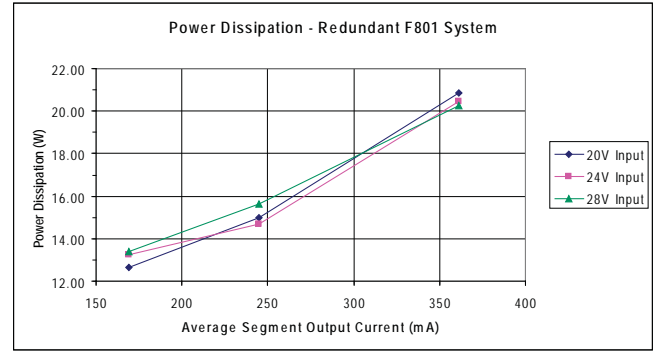
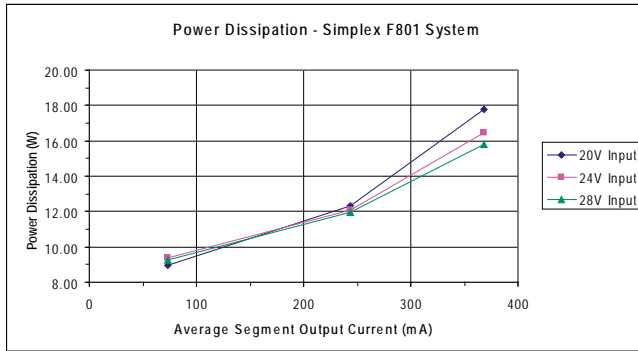
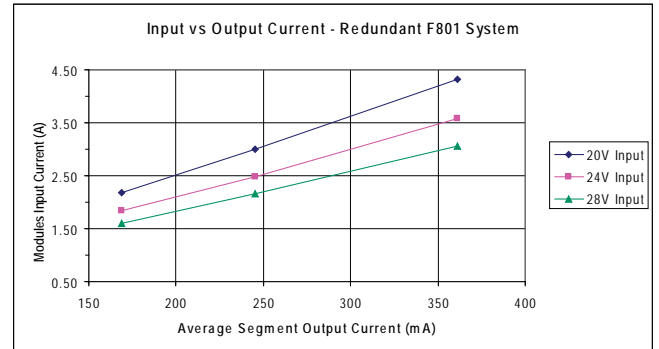
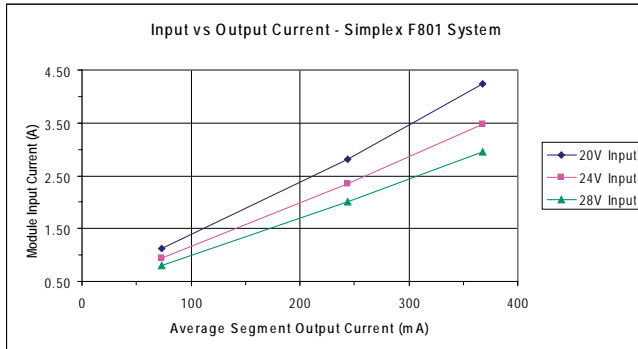

F802 PARAMETERS

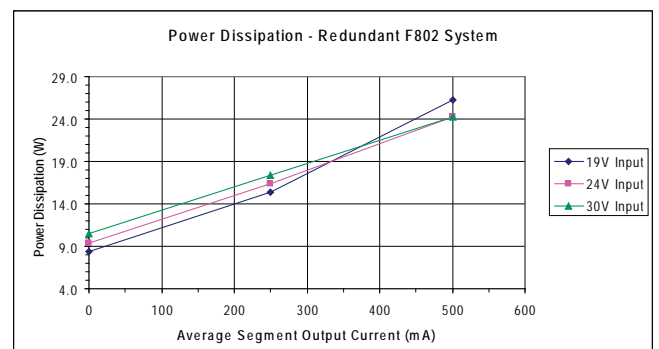
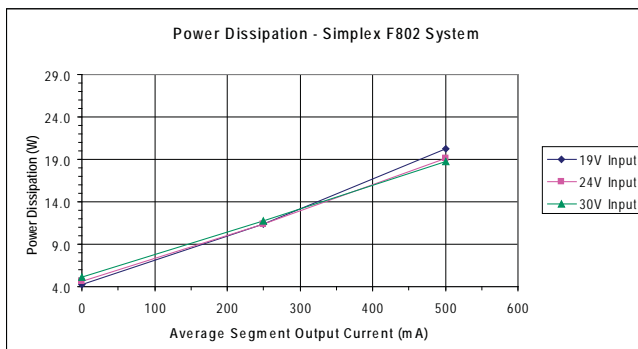
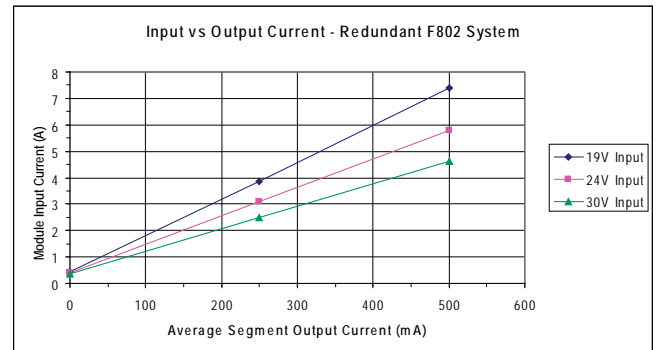
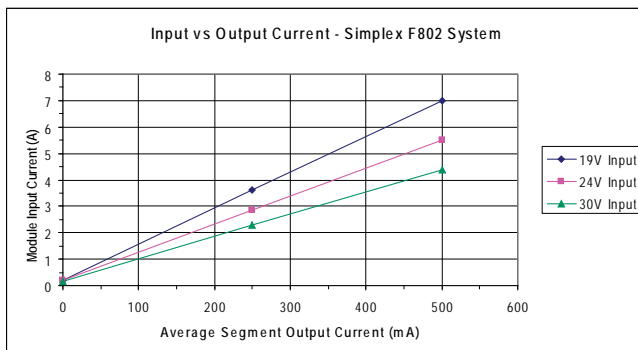

Linking alarm circuits

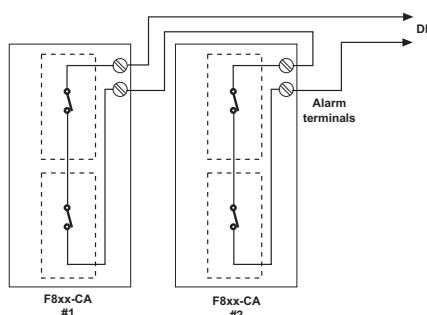

F80x module top panels showing indicators

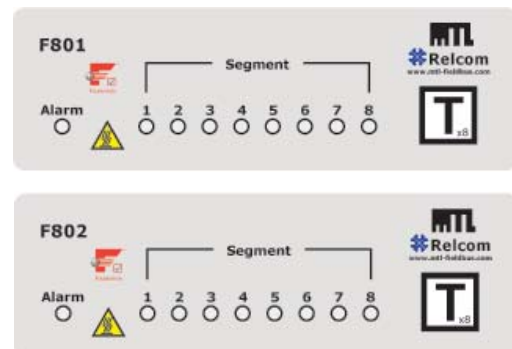

EUROPE (EMEA)
AMERICAS
ASIA PACIFIC

Tel: +44 (0)1582 723633
Tel: +1 281 571 8065
Tel: +65 6 487 7887

Fax: +44 (0)1582 422283
Fax: +1 281 571 8069
Fax: +65 6 487 7997

E-mail: enquiry@mtl-inst.com MTL web site: www.mtl-fieldbus.com Relcom web site: www.relcominc.com

F890:
PS-056 F890 Product Specification
Revision: F
www.relcominc.com

F890-P* DIMENSIONS

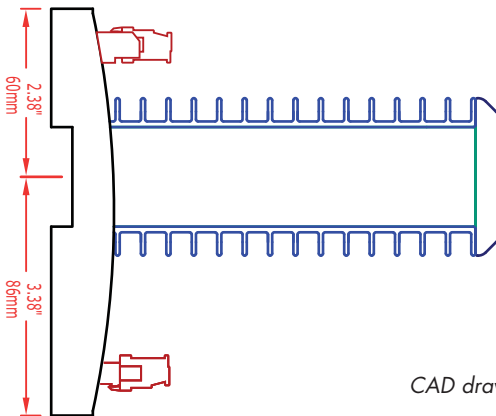
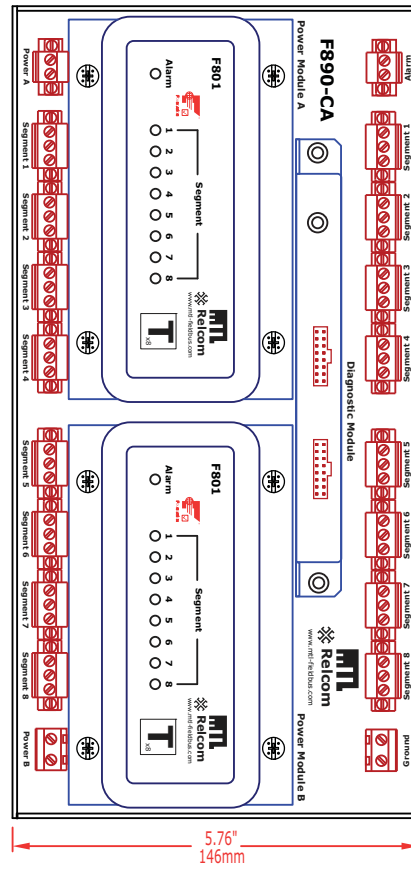
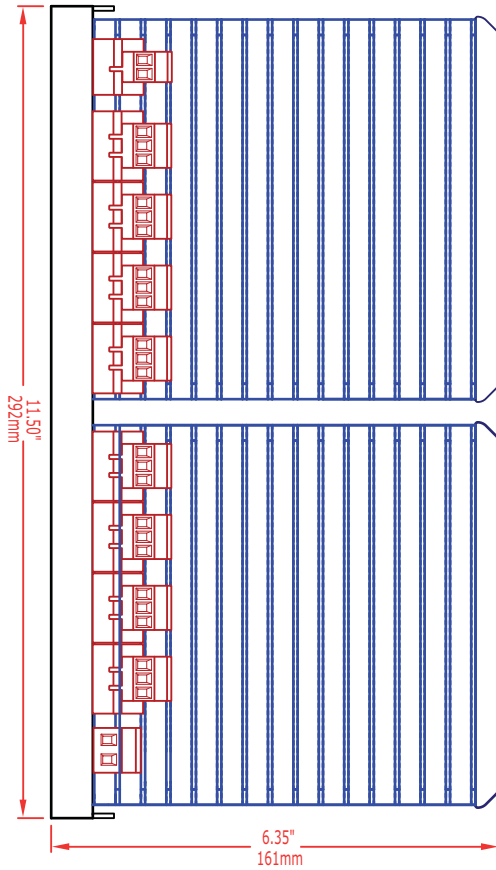

Shown using F801 power modules.
Overall dimensions are the same
when F802 modules are fitted.

CAD drawings are available on-line at www.mtl-fieldbus.com

APPROVALS - for the latest certification information visit www.mtl-inst.com/certs_1.nsf

Region (Authority)	Standard	Certificate	Approved for	Ratings
EU (Relcom)	EN61326		Class A Industrial Locations	CE
(FIELDBUS foundation™)	FF-831	PS001700 - (F801) PS001900 - (F802)		Power Supply Type 132
US (FM)	3600 3611 3610	3025124 - (F801) 3033657 - (F802)	Class I, Div 2, ABCD, T4 Class I, Zone 2, IIC, T4	V _{max} = 24V (F801) = 30V (F802)
Canada (FM)	C22.2 No. 213 C22.2 No. 142	3025124C - (F801) 3033657C - (F802)	Class I, Div 2, ABCD, T4 Class I, Zone 2, IIC, T4	V _{max} = 24V (F801) = 30V (F802)
EU (Relcom)	IEC 60079-0:2004 IEC 60079-15:2005	RELCO7ATEX1002X (F801 + F802)	Ex nA IIC T4	U _o = 24V (F801) = 30V (F802)



EUROPE (EMEA)
AMERICAS
ASIA PACIFIC

Tel: +44 (0)1582 723633
Tel: +1 281 571 8065
Tel: +65 6 487 7887

Fax: +44 (0)1582 422283
Fax: +1 281 571 8069
Fax: +65 6 487 7997

E-mail: enquiry@mtl-inst.com MTL web site: www.mtl-fieldbus.com Relcom web site: www.relcominc.com

F890:
PS-056 F890 Product Specification
Revision: F
www.relcominc.com