

Installation Instructions

FPS-I and FPS-2

Redundant Fieldbus Power System

1010.1 Equipment Information

Equipment Class II, Pollution Degree 2, Installation Category I

Maximum Altitude: 2000m

Humidity: 0 to 90% (non-condensing)

Operating Temperature: -40°C to 60°C (-40°C to 50°C if installed on vertical DIN rail)

For Indoor Use Only (IP 54 minimum enclosure)

Installation

WARNING: Do not remove or install an Isolated Power Module (IPM) unless the area is known to be non-hazardous.

Refer to the Control drawing included in this document for a typical installation. The drawing is intended to address the safety aspects of Class I, Division 2 areas. Actual segment connections may vary depending on factors such as the required number of Fieldbus segments.

Mounting

Relcom redundant Fieldbus Power Systems (FPS) are designed for mounting on 35mm DIN rail inside of an enclosure with a minimum rating of IP 54. Use of DIN rail end stops is recommended.

DIN rail mounting may be horizontal or vertical.

Note: Operating temperature range is -40°C to 50°C if installed on vertical DIN rail.

Once all wiring connections have been made, the retaining screws on each pluggable cable connector should be securely fastened.

Input Power Supply Connections

For redundant operation, two separate input DC power supplies should be connected to each FPS. Four pairs of terminals are provided on each FPS for this purpose; two pairs for each input power supply.

The extra pair of terminals for each input power supply are intended to be used for connection to another FPS installed immediately adjacent to the first. A prefabricated jumper assembly is included with each FPS for this purpose.

In most installations the distance from a bulk power supply to the FPS is less than 30m. If the distance from the bulk power supply to the FPS is in excess of 30m, then a suitable Surge Protection Device should be used.

When multiple Fieldbus Power Systems are wired together using jumper assemblies, redundant connections should be made to the two input power supplies using the terminal pairs located at each end of the row of systems. An example of multiple systems wired this way is shown in Figure 2.

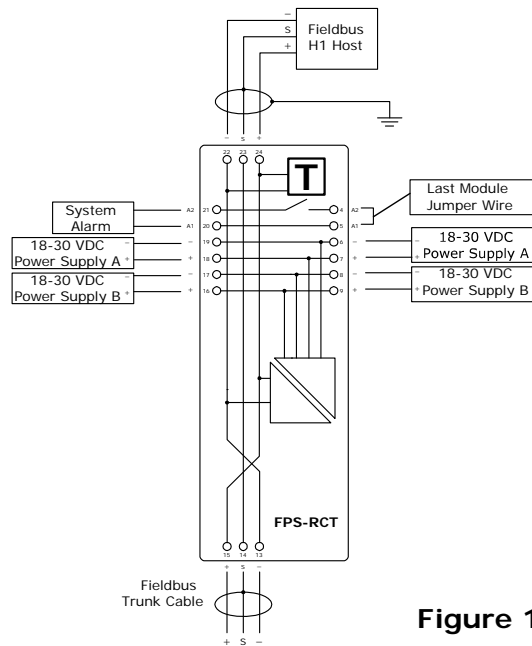

Figure 1



Relcom Inc.

INDUSTRIAL LAN | WIRING COMPONENTS AND TESTERS

Input Power Supply Connections (continued)

Multiple segments can be wired together using the supplied jumper assemblies. Relcom recommends a maximum of eight wired together segments based upon a maximum current limit of 8 Amps to the input power terminals of the FPS units. Both of the input power supplies (indicated in Figure 2 as "Power Supply A" and "Power Supply B") should be connected to the terminals at each end of the array of FPS units. When wired this way, any one of the eight units can be disconnected from the system without interrupting the operation of the others.

Note that the alarm terminals are connected to the system alarm at one end of the array and that the two terminals at the opposite end are connected to one another using a short length of wire. When wired in this way, the normally closed alarm circuit will open if a fault occurs in either of the input power supplies or any of the isolated power modules.

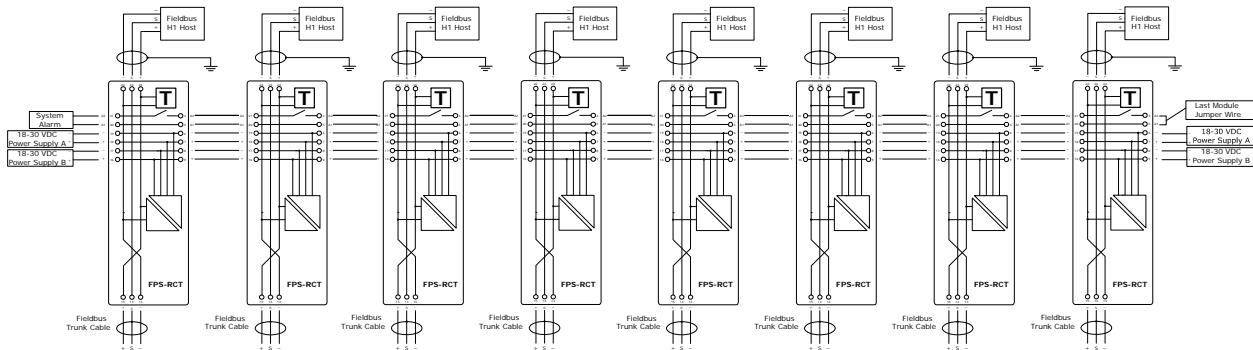

Figure 2

If a single redundant input power supply is used instead of two separate supplies, connect the input power supply to one set of terminals at each end of the array of FPS units and install jumpers from the first set of power supply terminals to the second set at each end of the array. This prevents the alarm circuit from falsely activating due to a lack of power on the second set of power input terminals.

Fieldbus Segment Terminators

Two terminators are required for each Fieldbus H1 network segment. The FPS-I has one terminator built into the backplane unit (part number FPS-RCT). This is indicated by the big "T" on the product label. The second Terminator should be positioned at the opposite end of the segment trunk cable. The FPS-2 has no terminator built into its backplane unit (part number FPS-RC).

Alarm Wiring Connections

Next to the input power terminals, terminal pairs are provided for connection of the alarm circuit. Refer to Figure 2. An alarm system is connected to the alarm terminals at one end of the array of FPS modules. Connect a prefabricated jumper assembly (included with each FPS unit) between each FPS in the array. Each prefabricated jumper assembly includes a pair of wires for the alarm circuit. Note that if only one FPS unit is installed, no prefabricated jumper is necessary. Connect a jumper wire across the alarm terminals of the last FPS in the array as shown.

During normal operation, the alarm circuit is closed. It will open if:

- Either input power supply < 18 VDC
- Output of either power module < 22 VDC
- The Fieldbus is shorted

H1 Host and Fieldbus Trunk Connections

Two 3-conductor (+, shield, and -) connectors are provided for connection to the H1 host and to the Fieldbus trunk cable.

A Green LED next to the connector labeled "Fieldbus" indicates that power is being supplied to the Fieldbus segment.

Testing/Troubleshooting

Check that both Power A and Power B Green LEDs are on. If they are not lit, check the input power connections.

Check that the Green LEDs on each of the two isolated power modules are on. If they are not lit, check module connections. If the connection is secure, replace the module.

Check that the Green Fieldbus LED is on. If it is not lit, check the Fieldbus cable and H1 host connection for short circuit.

If a system alarm is generated, check all LEDs on the FPS units in the alarm circuit. Follow the instructions above.

Operation

During normal operation, the green Power In A, Power In B, Fieldbus, and Power On LEDs should be lit.

If any of these LEDs are not lit, follow the instructions in the Testing/Troubleshooting section.

Maintenance Requirements

The FPS-I and FPS-2 contain no user serviceable parts. No maintenance is required. Non-functioning units should be returned to the manufacturer for replacement or repair.

For Further Information

Contact your local MTL representative or Relcom, Inc. as listed at the bottom of this page.

